

# 产品尺寸图 (DIMENSION)

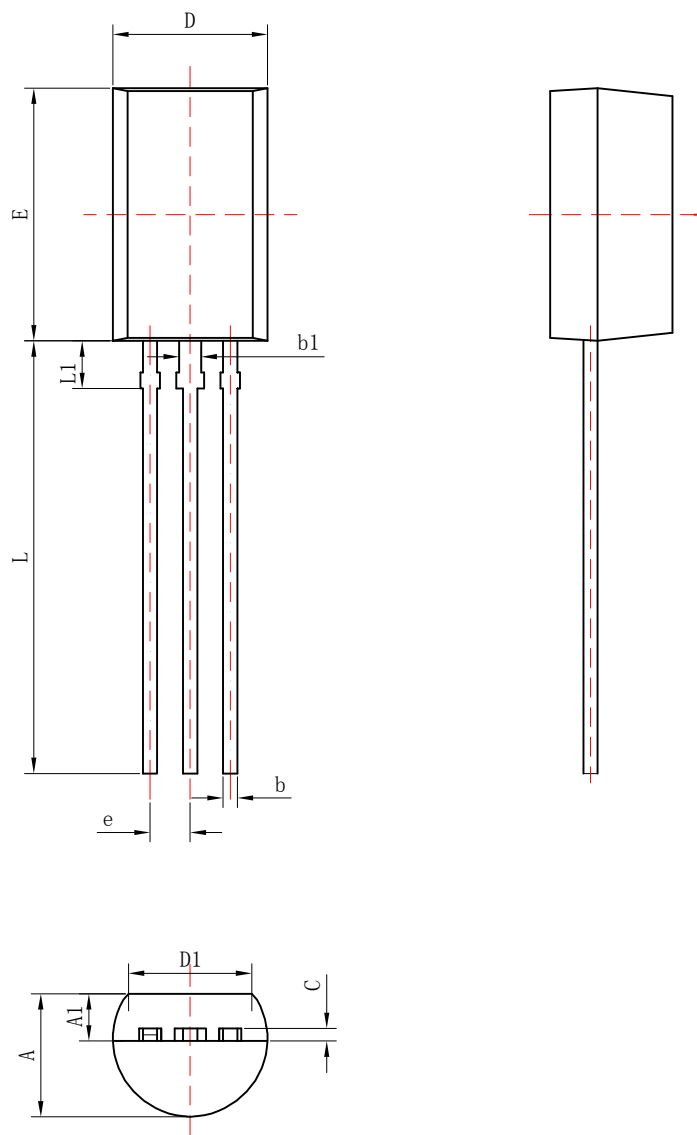

	symbol	Dimensions In Millimeters			Dimensions In Inches		
		Min	Nom	Max	Min	Nom	Max
	A	3.70	3.90	4.10	0.146	0.154	0.161
S.C	A1	1.40	1.50	1.60	0.055	0.059	0.063
S.C	b	0.35	0.45	0.55	0.014	0.018	0.022
	b1	0.60	0.70	0.80	0.024	0.028	0.031
	C	0.35	0.40	0.45	0.014	0.016	0.018
	D	4.70	4.90	5.10	0.185	0.193	0.201
	D1	3.80	-	-	0.150	-	-
	E	7.80	8.00	8.20	0.307	0.315	0.323
	e	1.27 TYP			0.050 TYP		
	L	13.20	13.70	14.20	0.520	0.539	0.559
	L1	1.50	1.60	1.70	0.059	0.063	0.067

# FSMC

图名 NAME	T0-92NL		图号 DWG. NO.	DD0079	SH 1 OF 1
材质 MATERIAL	Cu/Fe		REV.	D	
单位 UNITS	MM[INCH]	核准 APPROVE	审核 CHECKED	制图 DRAWN	 第三角法
日期 DATE	2020. 11. 17				
比例 SCALE	N. T. S.				